



Modular ice maker - Granular system
Daily production up to 1000 kg

Hotel	████████████████████
Restaurant	████████████████████
Fast food	████████████████████
Bar	████████████████████
Disco	████████████████████
Fish market	████████████████████
Supermarket	████████████████████
Medical & SPA	████████████████████
Industry	████████████████████

► Position n°



► Features & Plus

- Granular ice - 80-82% dry
- 1l (water) - 1kg (ice)
- AISI 304 SS Scotch Brite finish
- Tropical class +43°C
- Specific volume 1 m³ = 550 kg of ice
- AISI 304 SS evaporator
- Dust-proof water basin
- RoHS Free
- ON-OFF rocker switch
- Rotation sensor on low speed shaft
- Automatic water charge
- Standard and special voltages
- Frame in INOX



AISI 304 SS evaporator



Dust-proof water basin



Rotation sensor on low speed shaft



Frame in INOX

► Usable Bins

- Bin 550V DS
- Double Roller Bin 500
- Double Roller Bin 1200

2 Years Warranty
subject to limitations

► Certifications available for this model





Ice Flakes

G 1000 Split



Modular ice maker - Granular system
Daily production up to 1000 kg

► Working conditions

- Location: **Indoor**

	Min	Max
Ambient temperature	+10° C / +50° F	+43° C / 110° F
Water temperature	+3° C / +37° F	+32° C / +90° F
Voltage	-10%	+10%
Water inlet pressure	1bar (14 psi)	6bar (84 psi)

► Connections

- ① Water inlet
- ② Water outlet
- ③ Remote connection
- ④ Electrical connection
- ⑤ Refrigerant feeding pipe
- ⑥ Outlet pipe of gaseous refrigerant

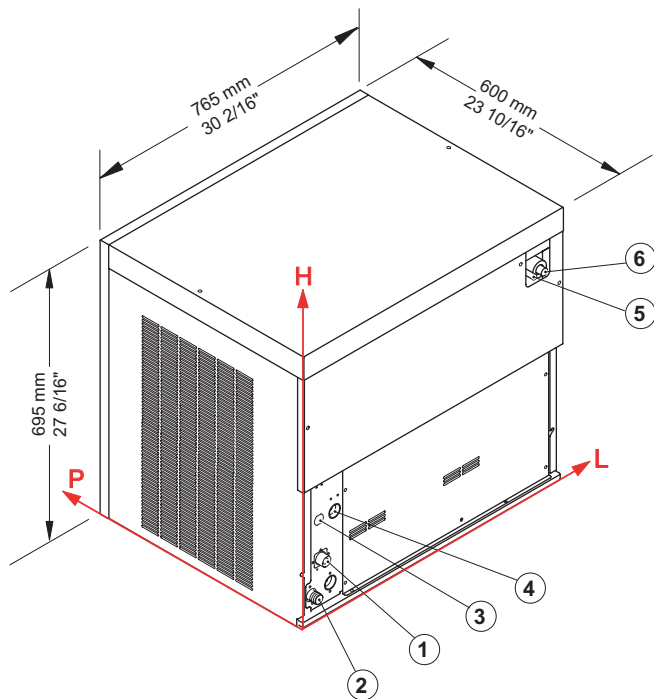

Installation



► Technical information

Production in 24h	1000 kg / 2205 lbs
Refrigerant	R404A - R507 - R448A - R449A - R407F - R452A
Refrigerant capacity	4600W (evap. temp. -18° C)
Water consumption	1 l/kg - 12,0 gal/100 lbs
Standard voltage	220-240 V ~ 50 Hz
Average power consumption	350 W
Finish	AISI 304 stainless steel, scotch brite

Sizes (L-P-H mm)	765 - 600 - 695
(L-P-H in)	30 2/16 - 23 10/16 - 27 6/16
Sizes with pack (L-P-H mm)	860 - 690 - 890
(L-P-H in)	33 14/16 - 27 3/16 - 35 1/16
Net weight	118 kg / 260 lbs
Gross weight	132 kg / 291 lbs

All the technical information need to be considered at the following conditions:
Refrigerant capacity 4600W (evap. temp. -18° C)
Water temperature +15° C
Average power consumption at +43° C (standard voltage)

Models and specifications are subject to change without notice

Rev. 04 - Issued September 2019



www.bremaice.it
info@bremaice.it

Bim + Data
download